

S1 TYPE--HC-49/US PACKAGE
Standard Specifications

Frequency Range (MHz)	3.200~70.000
Mode of Vibration	3.200~30.000MHz Fundamental 27.000~70.000MHz 3 rd Overtone
Drive Level (mW)	0.1 TYPICAL
Load Capacitance (pF)	8.0pF MIN
Frequency Tolerance (ppm)	± 10、 ± 30、 ± 50(at 25°C)
Shunt Capacitance(pF)	7 MAX
Operating Temperature Range	0°C~+70°C Standard
Frequency Stability (refer to 25°C)	± 30ppm Standard
Storage Temperature Range	-40°C~+85°C
Aging (First Year)	± 5ppm(at 25°C)

Equivalent Series Resistance

Frequency Range (MHz)	ESR MAX (Ω)	Frequency Range (MHz)	ESR MAX (Ω)
3.200~3.499	300	7.000~8.999	80
3.500~3.999	200	9.000~12.999	60
4.000~4.999	150	13.000~19.999	40
5.000~5.999	150	20.000~30.999	30
6.000~6.999	100	27.000~70.000	100

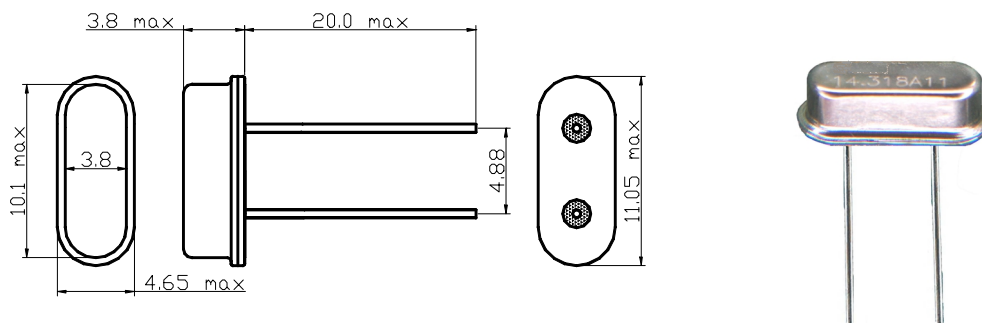

All Dimensions in mm